

TEST LABORATORY

Notified Body N° 2061

MECHANICAL REPORT TEST ON NON-TRADITIONNAL FLOOR MOUNTING GLASS RAILLING SYSTEM

RA-GCO0074

Profile: KF 1050

Wedge: Holding

Glazing: 10/10/4

Length 1000 mm

Category: C1-C2-C3-C4-D [Public]

Applicant: GCD France
270 Rue des Carrières
69440 TALUYERS

Testing date: 23-Nov-20
Writing date: 10-May-21

Usine : Besan Metal İnşaat Taahhüt San. Ve Dış Tic. Ltd. Şti.
Ziya Gökalp, A -1 Blok, Bixsan Sanayi Sitesi 25-28,
34490 İkitelli Osb/Başakşehir, Turquie

Any reproduction of this test report is forbidden except for full photographic facsimile

This report contains 15 pages (including 3 pages of appendix)

PR 05-3/32 - Mechanical report test on glass railing system



04 75 58 59 50



bienvenue@ceribois.com



Rovaltain 14 rue Brillat Savarin
CS 11168 Châteauneuf-sur-Isère – 26958 Valence cedex 9

www.ceribois.com

TABLE OF CONTENTS

| | |
|---|----------------|
| 1. SUMMARY | Page 3 |
| 1.1. TEST SPECIMEN..... | Page 3 |
| 1.2. PERFORMANCE RESULTS SUMMARY | Page 3 |
| 2. SUBJECT MATTER | Page 4 |
| 3. REFERENCE TEXTS | Page 4 |
| 4. TEST CONDITIONS | Page 4 |
| 5. TEST SPECIMEN DESCRIPTION | Page 5 |
| 6. STATIC TESTS | Page 6 |
| 6.1. HORIZONTAL OUTWARD STATIC TEST | Page 6 |
| 6.1.1. Deformation test under imposed load description | Page 6 |
| 6.1.2. Safety load test description | Page 8 |
| 6.1.3. Horizontal static outward test results | Page 8 |
| 6.2. HORIZONTAL INWARD STATIC TEST | Page 9 |
| 6.2.1. Test description | Page 9 |
| 6.2.2. Test results | Page 9 |
| 7. RAILING FILLING IMPACT TESTS | Page 10 |
| 7.1. SOFT BODY IMPACT TESTS | Page 10 |
| 7.1.1. Soft body impact test description..... | Page 10 |
| 7.1.2. Soft body impact test results | Page 11 |
| 7.2. HARD BODY IMPACT TESTS | Page 11 |
| 7.2.1. Hard body impact test description | Page 11 |
| 7.2.2. Hard body impact test results | Page 12 |
| 8. APPENDIX : PLANS | Page 13 |

1. SUMMARY

1.1. TEST SPECIMEN

| | |
|-------------------------------|---|
| COMPANY | GCD France - 270 Rue des Carrières - 69440 TALUYERS |
| Test specimen's name | KF 1050 - Holding Wedge - Glass 10/10/4 - Length 1000 mm |
| Target category | C1-C2-C3-C4-D [Public] |
| Date of receipt | November 18, 2020 |
| Ambient conditions | Temperature: 17,9 °C / Humidity: 49,5 % |
| Test specimen's number | CO-GCO0074 |

Company representative present to the tests:

Eric CHEMARIN - GCD France

Jean-Charles LACOSTE - GCD France

1.2. PERFORMANCE RESULTS SUMMARY

| | | |
|---|---|------------------|
| Horizontal outward static test C2-C3-C4-D [Public] | Imposed load 1 kN/ml Safety load 3 kN/ml | COMPLIANT |
| Horizontal inward static test | 40 daN | COMPLIANT |
| Soft body impact tests | 900 J 700 J | COMPLIANT |
| Hard body impact tests | 10 J 3 J | COMPLIANT |

Experimental justifications necessary for the evaluation of the suitability, of its capacity to ensure the safety of persons according to the Statement of Works n°3034 V3 - May 2019

| | |
|--|---|
| Test done on November 23, 2020 | Approbation |
| <i>Cyriane BIRANT</i> <i>Mechanical test technician</i> | <i>Jonathan FERNANDEZ</i> <i>Project Manager</i> |
| | |

2. SUBJECT MATTER

The mechanical tests made on non-traditional floor mounting glass railing system at CERIBOIS' test laboratory are the following:

1. Horizontal outward static test
2. Horizontal inward static test
3. Soft body impact tests
4. Hard body impact tests

3. REFERENCE TEXTS

The tests are made following the following documents and Standards:

- **Statement of Works n°3034 V3 (May 2019)**
 - **NF P 01-013 (august 1988): RAILINGS TESTS - Methods and criteria**
 - **NF EN 1991-1-1 (March 2003): Eurocode 1 - Actions on structures and its National Annex NF P 06-111-2/A1 (March 2009)**
- **The following test results are only referring to the tested specimen described in "Test specimen description" section of this document.**
- **The test results don't take into account the uncertainty of measurement associated.**
- **The vertical load test and the wind resistance test were not requested; therefore, they were not performed.**

4. TEST CONDITIONS

- Test laboratory CERIBOIS at Valence (26)
- Railing parts (specifically glazing) have been stocked in laboratory weather conditions at least during four hours.
- CERIBOIS' measuring equipment (Dial gauge, force sensor and thermo-hygrometer) are calibrated regularly in the context of CERIBOIS' usual activity following the regulatory requirements of Standard NF EN ISO/CEI 17025.
- The test specimen is rigidly attached onto the mechanical test bed. Its initial verticality is checked.

5. TEST SPECIMEN DESCRIPTION

Non-traditional floor mounting glass railing system: type A1:

- Continuously attached to the ground
- Without vertical framing
- Without handrail
- With only one span

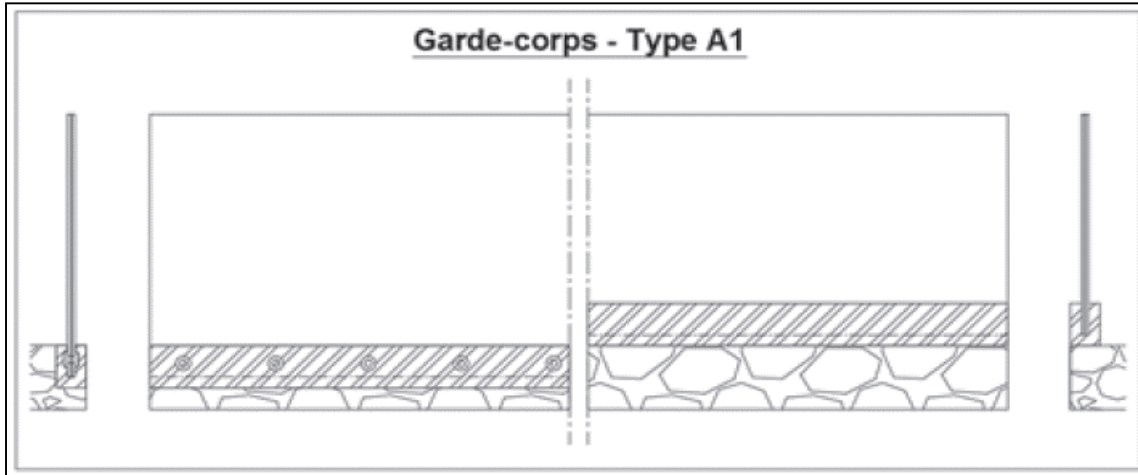

The railing mounting is realized by GCD France's staff, present during the tests.

It is described on the plans on the annex. The railing consists of the following:

| | |
|--------------------|--|
| Trade name | KF 1050 - Holding Wedge - Glazing 10/10/4 |
| Dimensions (H x L) | 1094 mm x 1000 mm |
| Profile | Railing profile KF 1050 (ANODISED ALUMINIUM), reference KOZZA - 1000.250.20. |
| Fasteners | 5 ground fasteners (10mm screws), center distance: 200 mm, without any specific torque. |
| Wedges | 4 mounting wedges Holding (Plastic), center distance: 250 mm without adjusting screws Reference: KOZZA - GLASSMOVE GM1010 |
| Glazing | 1 glazing: 10/10/4 (1060 mm - 1000 mm - 21,52 mm) (See the Identification sheet of the glazing in appendix) |
| Covers | No cover has been fixed to the tested railing |
| Seals | 2 seals (a stuffing and an interior) in ABS 30% et TPE 60SH |

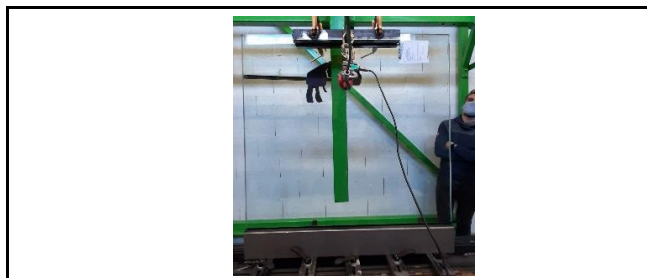

Full railing

6. STATIC TESTS

6.1. HORIZONTAL OUTWARD STATIC TEST

6.1.1. Deformation test under imposed load description

The railing is under an horizontal static load in the outward direction. This load is applied on the the top part of the glazing, at 1,094 m above the usual stationary area (ZSN).

This horizontal static load is characterised by the application of a force F from the inside outwards. The points of application of loads are shared with a maximum spacing of 0.35m, on the upper edge of the glazing.

The deformation is measured using a comparator after 3 minutes of application of the imposed load (Pe), applied gradually and without shock, up to the maximum value.

Please Note: Beforehand, a preload with the imposed load value Pe, has been applied during 1 minute in order for the different elements to fall into place.

The initialization of the comparator is done after this pre-loading and after returning to a stable state.

→ **Maximum permissible initial deformation: 35mm**

The Statement of Works n°3034 V3 asks to measure the deformation at 1 m above the Normal Parking Area

Residual deformation is measured 15 minutes after unloading.

→ **Maximum permissible residual deformation: 3mm**

The applied force F (in kN) is equal to $P_e \times L$

$$F = 1 \text{ kN/ml} \times 1 \text{ ml}$$

$$F = 1 \text{ kN}$$

P_e : Imposed load in kN / ml

L : Railing length in ml

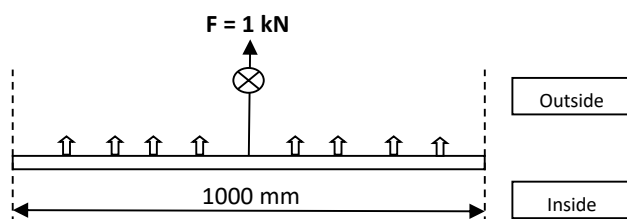

Schematic of the test

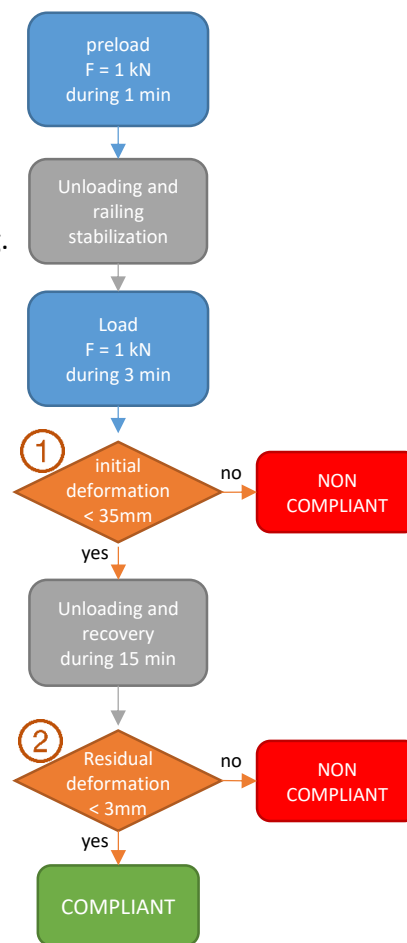

Imposed load test flowchart

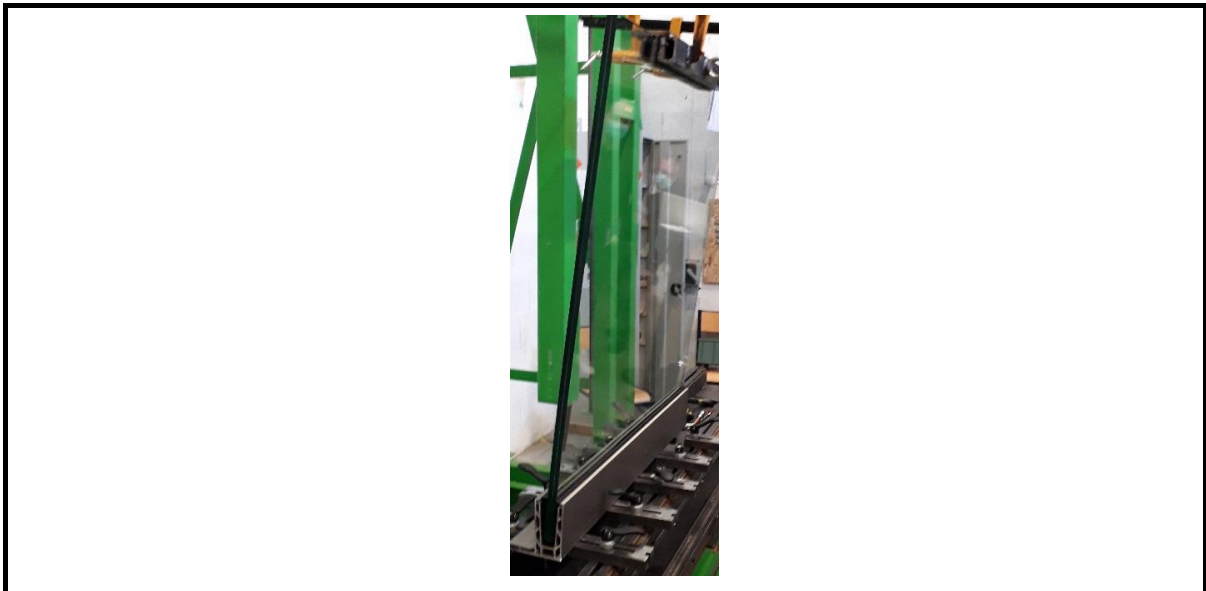

Railing under imposed load P_e

According to railing categories of the standard NF P 06-111-2A1 : 2009, P_e values are according to the following:

| Category | Specific use | P_e load |
|----------|------------------------------------|------------|
| A | Housing | 0,6 kN/ml |
| B | Office | 0,6 kN/ml |
| C1 | Meeting areas with tables | 1,0 kN/ml |
| C2 | Meeting areas with fixed seats | 1,0 kN/ml |
| C3 | Meeting areas without obstacles | 1,0 kN/ml |
| C4 | Meeting place for sport activities | 1,0 kN/ml |
| C5 | Meeting place hosting large crowds | 3,0 kN/ml |
| D | Shops | 1,0 kN/ml |

Category of use chosen by the client: C1-C2-C3-C4-D [Public], with a load of 1 kN/ml.

6.1.2. Safety load test description

Railing under increased imposed load (Ps) by a coefficient of 3, applied during 15 minutes.

The applied load F (in kN) is equal to Ps x L

$$F = 3 \times P_e \times L$$

$$F = 3 \times 1 \text{ kN/ml} \times 1 \text{ ml}$$

$$F = 3 \text{ kN}$$

→ This test must not lead to to any ruin of the test body (breakage of gazing, fasteners, ...)

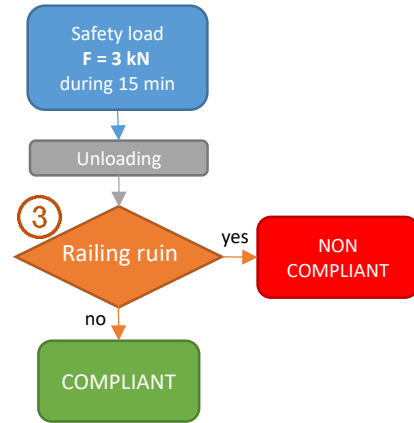

Safety load test flowchart

6.1.3. Horizontal static outward test results

| | Applied force | Criteria number | Criteria | Test result | STATEMENT |
|---------------------------------------|---------------|-----------------|--|-------------|-----------|
| HORIZONTAL OUTWARD STATIC TEST | F = 1 kN | ① | Intial deformation < 35 mm | 27,10 mm | COMPLIANT |
| | F = 0 kN | ② | Residual deformation < 3 mm after 15 min | 1,87 mm | COMPLIANT |
| SAFETY LOAD TEST | F = 3 kN | ③ | Must not ruin the railing | No failure | COMPLIANT |

6.2. HORIZONTAL INWARD STATIC TEST

6.2.1. Test description

The railing is under an horizontal static load, applied on the top part of the glazing and at the center of its range, into the inward direction.

The static loads are applied at 1,094 m above the Usual Stationary Area (ZSN).

The load F applied during 1 minute is at minimum 40 daN per span.

The residual deformation is measured 15 minutes after unloading.

→ **Maximum residual deformation tolerated : 2 mm**

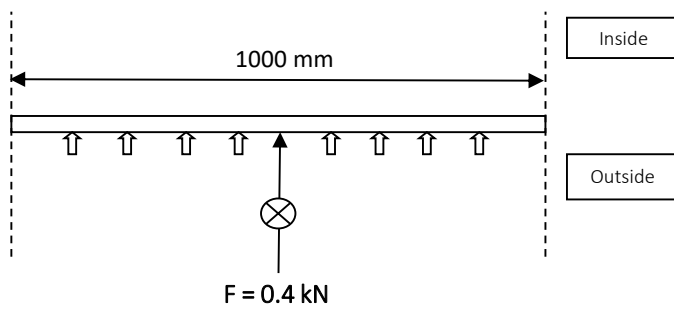

Schematic of the test

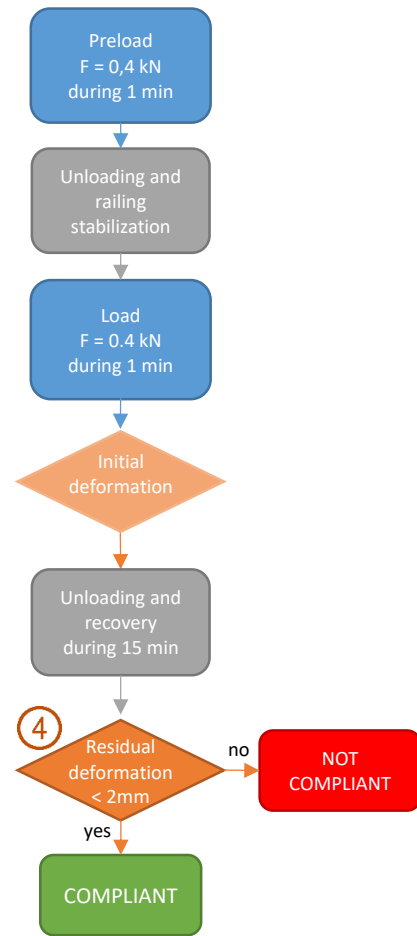

Inward static test flowchart

6.2.2. Test results

| | Applied force | Criteria number | Criteria | Test result | STATEMENT |
|--------------------|---------------|-----------------|--|-------------|-----------|
| INWARD STATIC TEST | 0.4 kN | ④ | Residual deformation < 2 mm after 15 min | 1,97 mm | COMPLIANT |

Please note: the initial deformation under the load applied during 1 minute was 25,64 mm.

7. RAILING FILLING IMPACT TESTS

7.1. SOFT BODY IMPACT TESTS

7.1.1. Soft body impact test description

The dynamic soft body test is performed using a shock body made of a spheroconic canvas bag filled with glass beads.

The shock body, suspended at an anchor point, falls with a pendulum movement and comes knocking perpendicular to its plane, the railing filling at determined points of impact.

Test performed at impact point with:

- 50 kg spheroconic canvas bag,
- Drop height H1 = 1.83 m or 900 J,
- Drop height H2 = 1.43 m or 700 J.

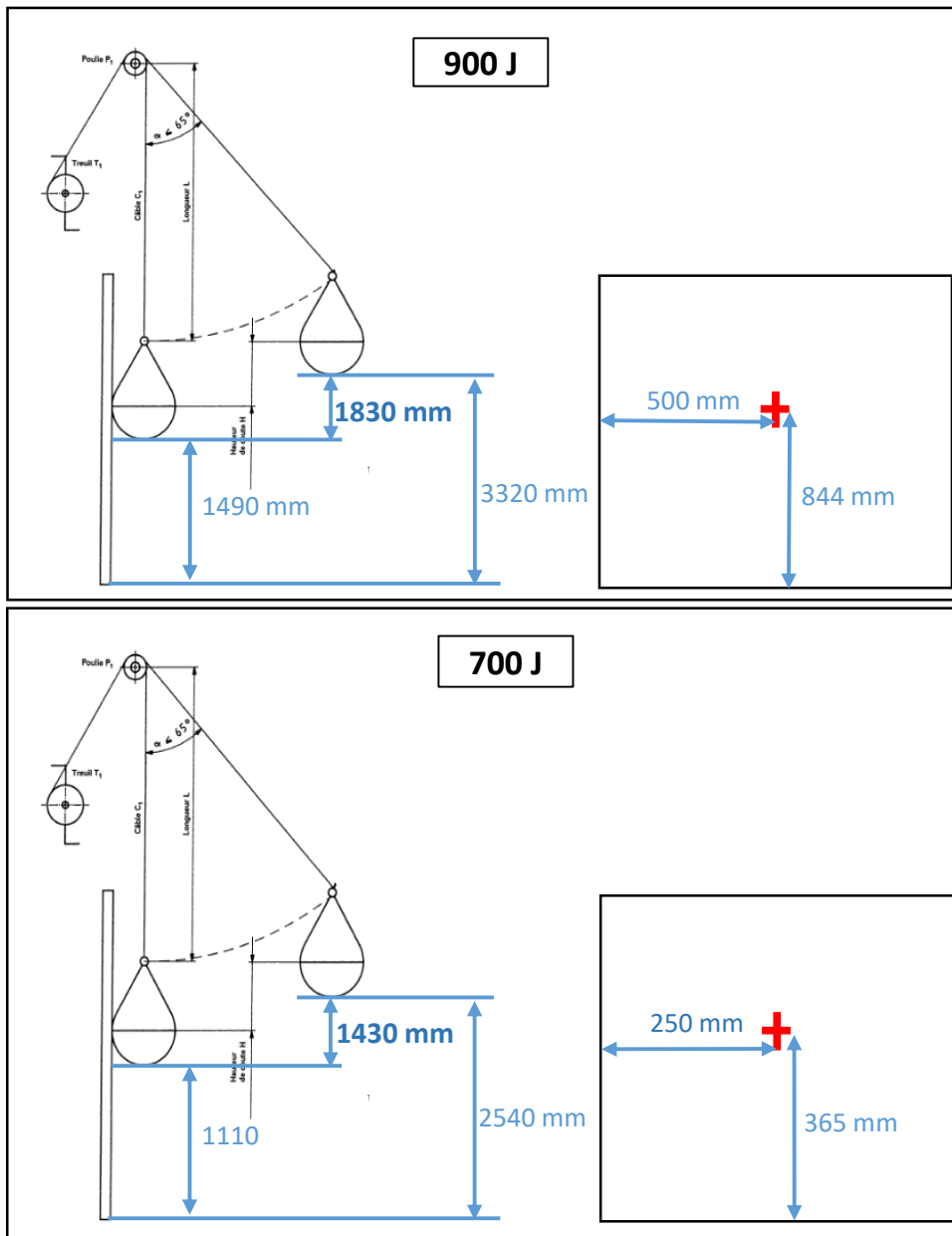

Two impact points are spotted:

- 900 J shock: at filling's mid-width and at 250mm from the upper edge of the glazing,
- 700 J shock: at 250mm from a vertical edge and at 1/3rd of the height.

→ **The railing must not be crossed, swept and must not provoke any debris fall**

7.1.2. Soft body impact test results

| Choc energy | Drop height | Shock position | Observations | STATEMENT |
|-------------|-------------|--|-----------------------|-----------|
| 900 J | 1.83 m | Filling's mid-width and at 250mm from the upper edge of the glazing | a wedge has blown out | COMPLIANT |
| 700 J | 1.43 m | At 250mm from a vertical edge and at 1/3rd of the height from the bottom | CLEAR | COMPLIANT |

7.2. HARD BODY IMPACT TESTS

7.2.1. Hard body impact test description

The dynamic hard body test is performed using a shock body mode of a steel ball.

The shock body, suspended at an anchor point, falls with a pendulum movement and comes knocking perpendicular to its plane, the railing filling at determined points of impact.

Test performed at impact point with:

- 1 kg steel ball
 - o Drop height H1= 1.02 m or 10 J
- 0.5 kg steel ball
 - o Drop height H2= 0.61 m or 3 J

Points of impact are either at the geometrical center of the filling, or at 250 mm on one side at mid-height of the visible part of the glazing.

- Security shock at 10 J

→ The railing must not be crossed, swept and must not provoke any debris fall

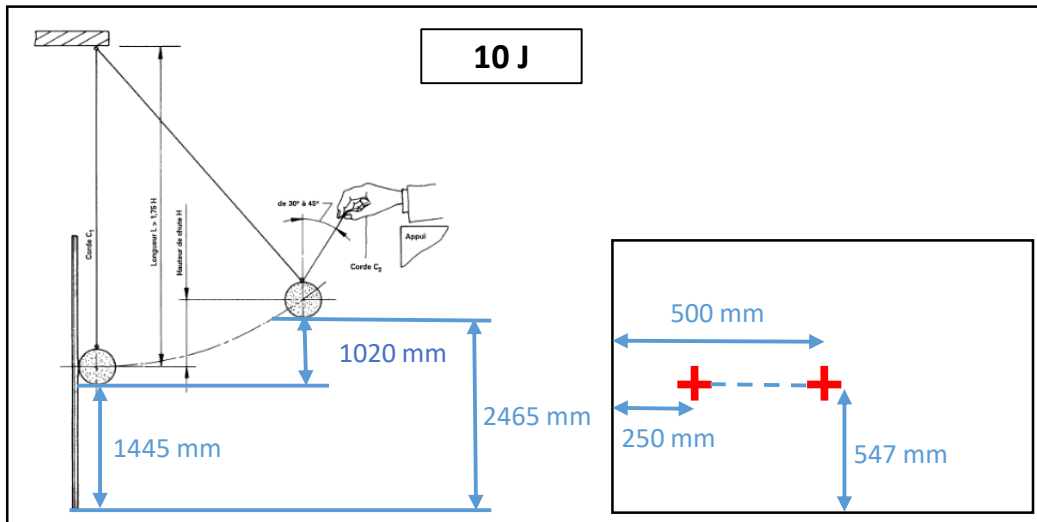

- Performance conservation shock at 3 J

→ The railing shouldn't be damaged

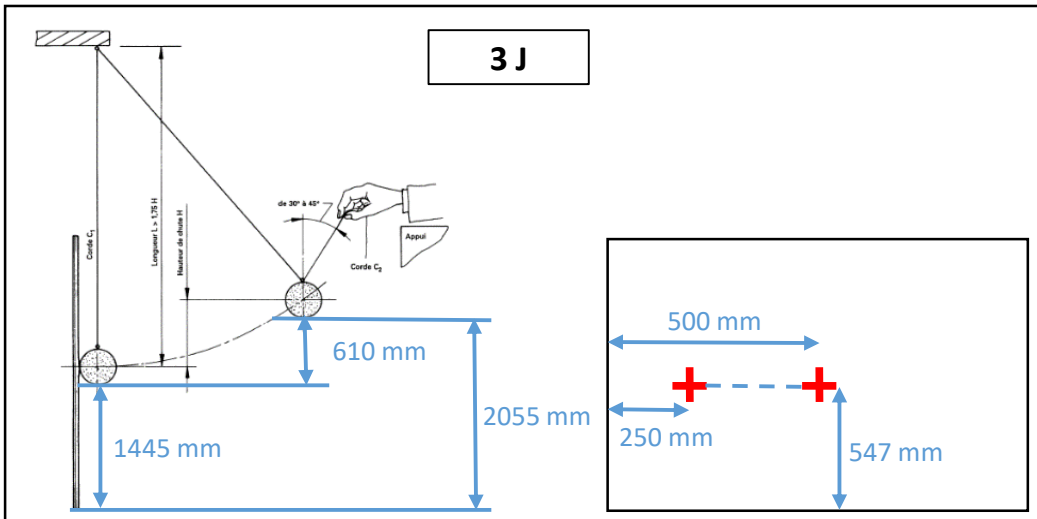

7.2.2. Hard body impact test results

| Shock energy | Drop height | Shock position | Observations | STATEMENT |
|--------------|-------------|---|--------------|-----------|
| 10 J | 1.02 m | Center of the filling | CLEAR | COMPLIANT |
| 10 J | 1.02 m | At 250mm from a vertical edge and at glazing mid-height | CLEAR | COMPLIANT |
| 3 J | 0.61 m | Center of the filling | CLEAR | COMPLIANT |
| 3 J | 0.61 m | At 250mm from a vertical edge and at glazing mid-height | CLEAR | COMPLIANT |

8. APPENDIX : PLANS



Wedge: Holding

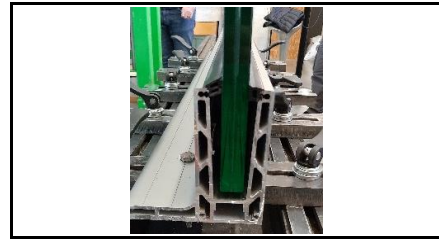

Profile: KF 1050

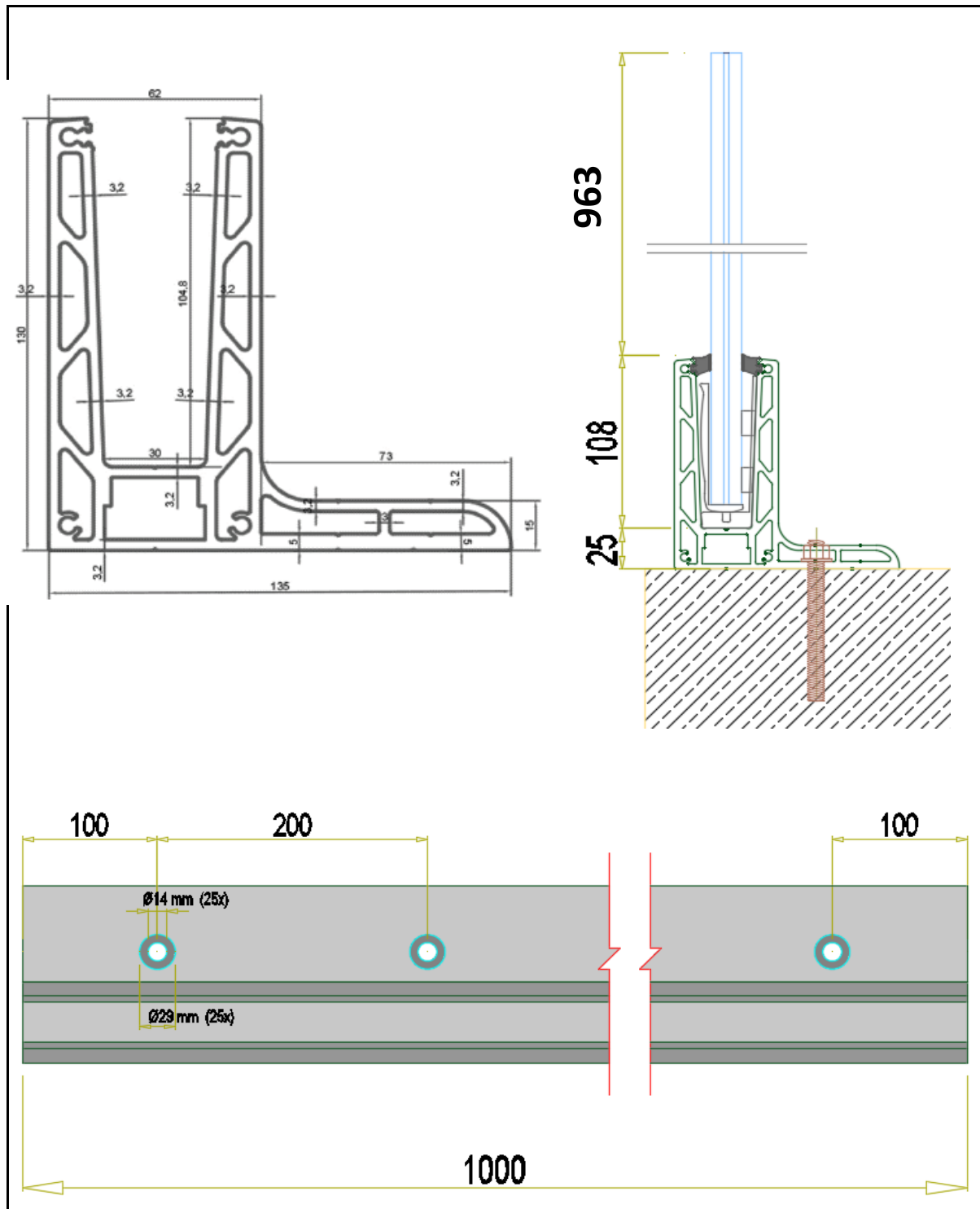

Profile plan

Annexe 1 Fiche d'identification du vitrage (à remplir par le fabricant de vitrage)

| Fiche d'identification du vitrage à renseigner par le fabricant Identification sheet of the glazing to be completed by the manufacturer | |
|---|-------------------------------|
| Nom du produit / Product name | Stratobel Structaflex |
| Nom du fabricant / Manufacturer name | AGC IVB |
| Nom de l'usine d'assemblage en feuilleté / Name of assembly plant for laminated glass | AGC IVB |
| Dimensions / Dimensions | 1650 x 1060 |
| Vitre 1 / Glass 1 | |
| - Épaisseur / Thickness | 10mm |
| - Traitement thermique / Heat treatment | Oui |
| - Façonnage des bords / Edge shaping | Joint Plat Poli |
| - Autres (sérigraphie, couches...) / Others (patterned, coating...) | / |
| - Mesure optique des précontraintes de surface des vitrages trempés ou durcis suivant la norme NF EN 14179 ou NF EN 1863 ou réalisation d'essais de flexion suivant NF EN 1288-3 / measurement of surface compression stress of thermally toughened or heat strengthened glass according to EN 14179 or EN 1863 or bending test according to EN 1288-3 | Programme de trappe 120MPa |
| Vitre 2 / Glass 2 | |
| - Épaisseur / Thickness | 10mm |
| - Traitement thermique / Heat treatment | Oui |
| - Façonnage des bords / Edge shaping | Joint Plat Poli |
| - Autres (sérigraphie, couches...) / Others (patterned, coating...) | / |
| - Mesure de contrainte de compression superficielle des vitrages trempés ou durcis suivant la norme NF EN 14179 ou les essais de flexion suivant NF EN 1288-3 / Optical surface pre-stress measurement of thermally toughened or heat strengthened glass according to EN 14179 or bending test according to EN 1288-3 | Programme de trappe 120MPa |
| Intercalaire / Interlayer | |
| - Nom du film / Interlayer name | Saflex R series (RB41) |
| - Fabricant / Manufacturer | Eastman |
| - Nature / Nature | Polyméthacrylate |
| - Épaisseur / Thickness | 1,52mm |
| - Date et signature du fournisseur de vitrage / Date and signature of glazing manufacturer | 12/11/2020 |

Fiche d'identification du vitrage (à remplir par le fabricant de vitrage)

AGC IVB
Zone Industrielle
10170 - MERY SUR SEINE
Tél. + 33 (0)3 25 39 52 52
Fax + 33 (0)3 25 39 52 39
SIRET 401 698 840 00014 - APE 2312 Z

AGC IVB
Zone industrielle
10170 Mery sur Seine
France
Tel: +33 3 25 39 52 52



SAS GCD france - 270 Rue des Carrières - P.A. de la Ronze - 69440 TALUYERS - Tél : 04 78 73 21 87

Identification sheet of the glazing

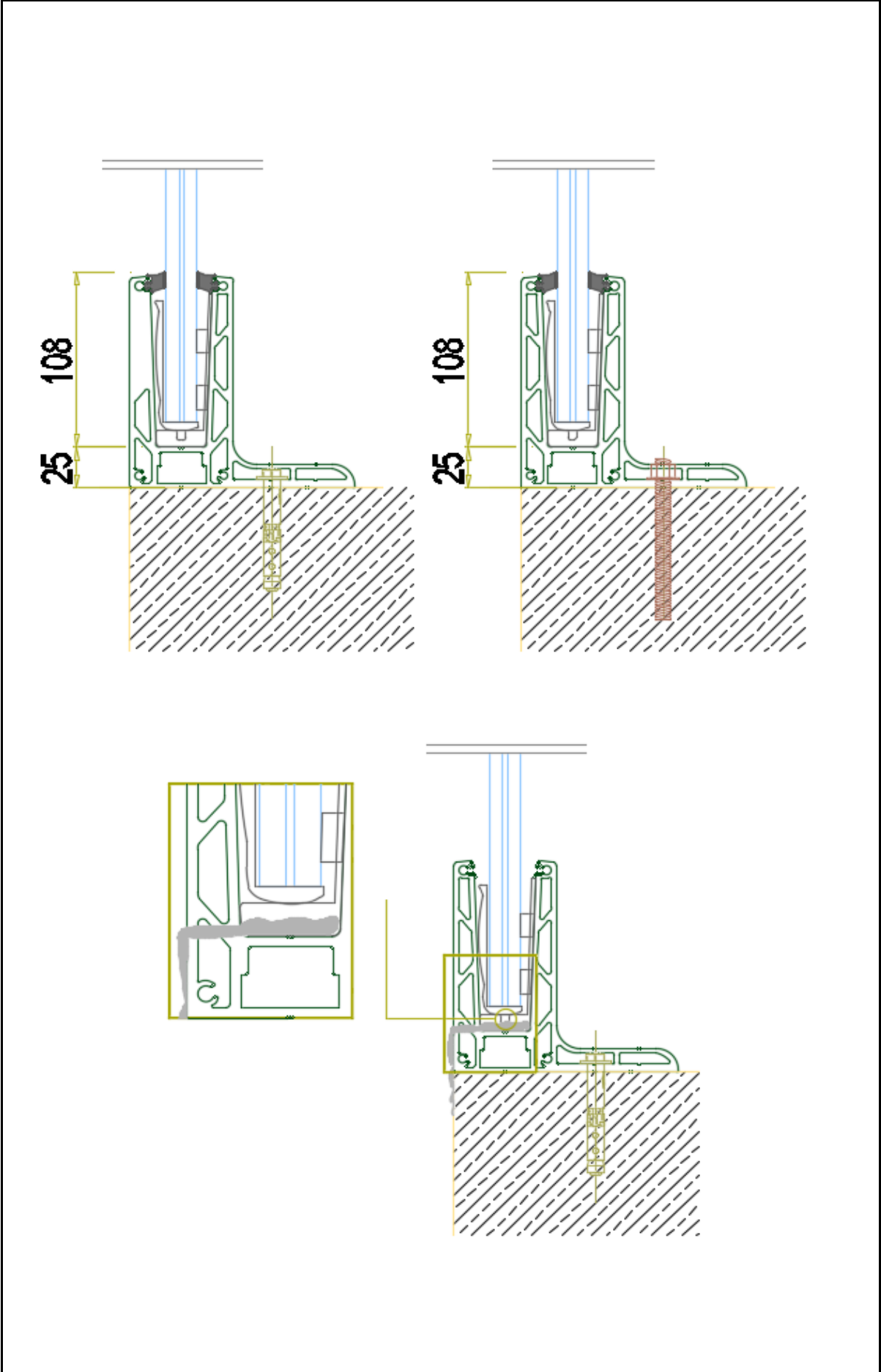

Profil detail (untested attachment)